



aperture

L-band Scatterometry for Ocean Winds in Extreme Conditions

Zach Kabelac, PhD, Aperture Earth

proprietary and confidential to aperture earth, inc.

Top-Tier Priority

- NOAA / National Weather Service:
#2 most important parameter 7-40% tropical measurements degraded by rain

Operational Mission Impact

- JTWC:
77% of their 6-hourly tropical cyclone analyses lack ocean wind vector observations

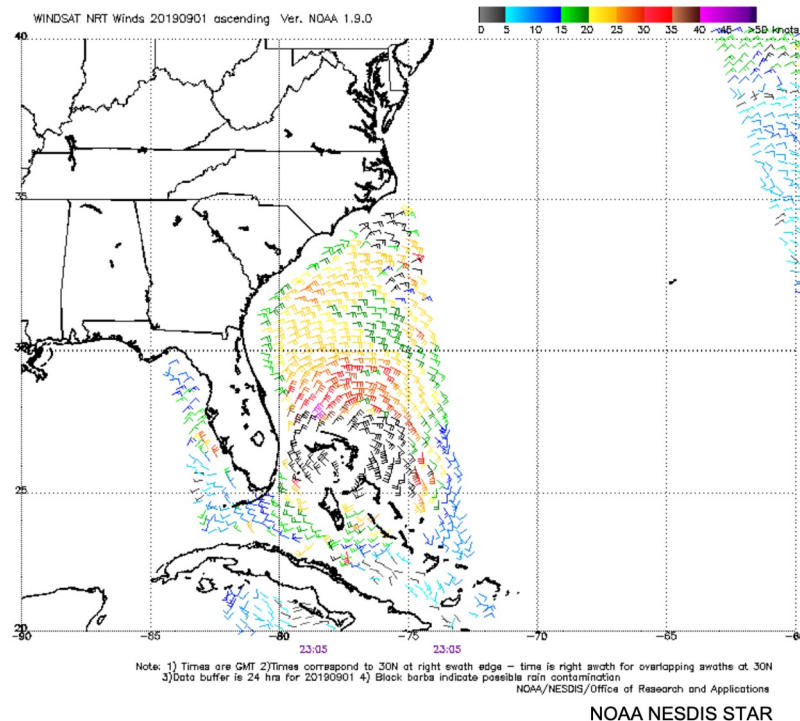

Global Active Radar (Scatterometers)

- a) METOP B/C (EU) - Co-Pol C-band Fan Beam
 - i) Reliable, but rain limited
- b) Oceansat-3 (ISRO) - Co-Pol Ku-band Pencil Beam
 - i) High resolution, but rain blinded

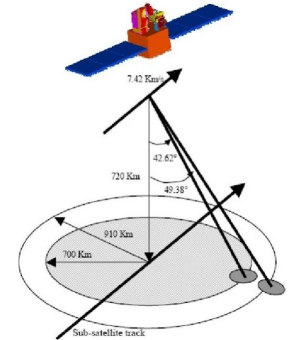
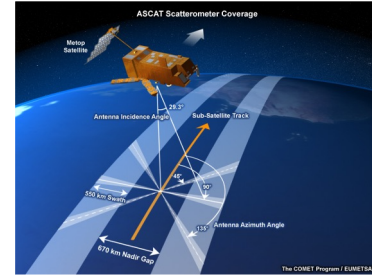

US Passive Microwave (Radiometer)

- a) WSF-M (USSF) - newest operational mission
 - i) 11, 19, 24, 37, 37.3, and 89 GHz passive sensing

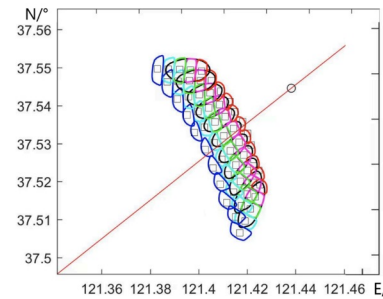

WSF-M (Passive) Limitations

- **Storm Blindness:** 10GHz minimum frequency cannot penetrate heavy rain/inner-cores.
- **Low-Wind Gap:** Polarimetric signal "flattens" below 7 m/s loses directional accuracy.

The "Wind Sensing" Void

- ZERO US operational scatterometers on-orbit since QuikSCAT / RapidScat.
- International satellites face accuracy challenges within storms.

L-band vs C-band vs Ku-Band: What is the Difference?

aperture **space**

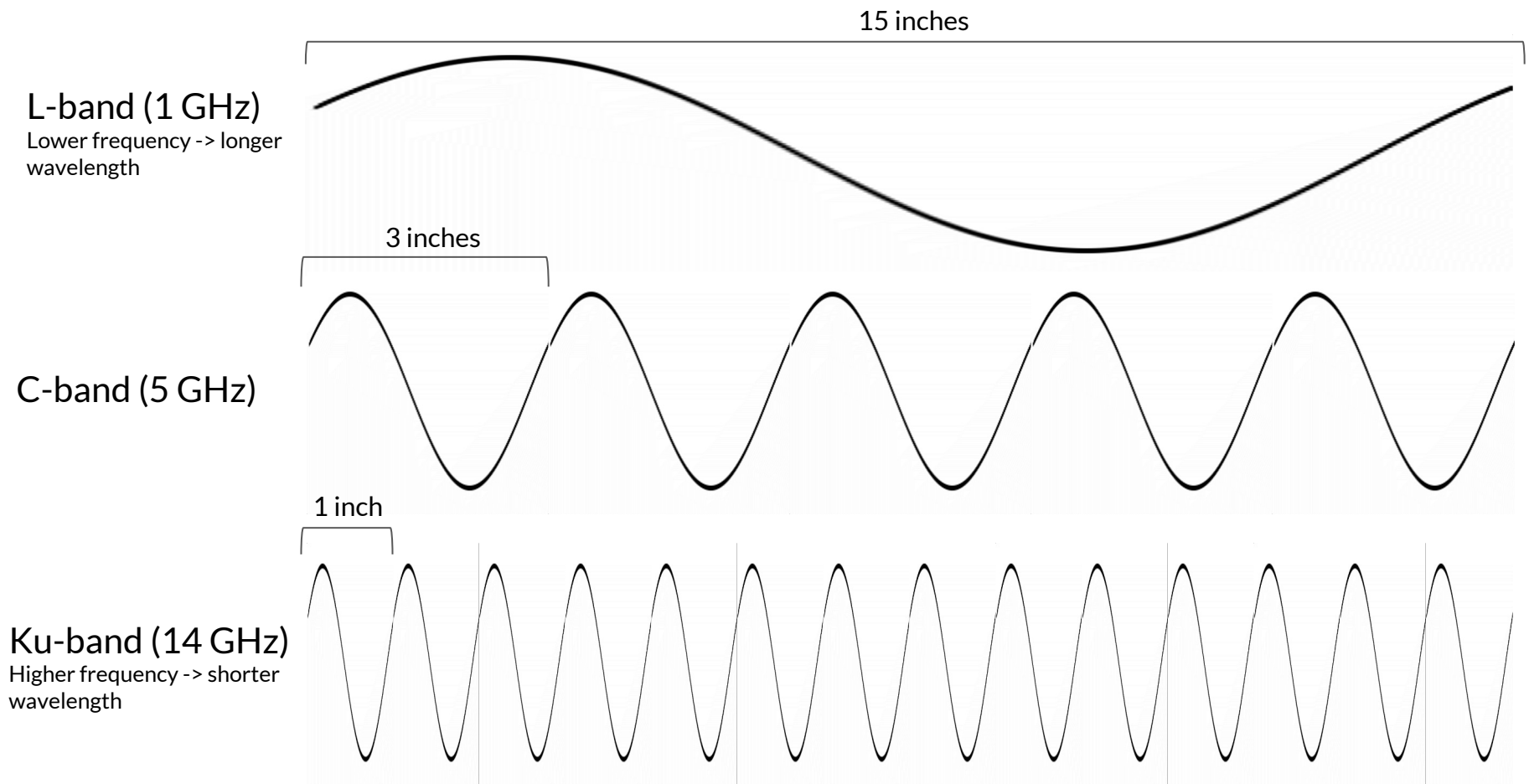

Resolving the Limitations of C and Ku-band in Extreme Conditions

- **Extended Wind Sensitivity**
 - No operational satellite scatterometers collect Cross-Pol (VH/HV). Aperture Cross-Pol L-band extends useful wind range toward 70 m/s, complementing existing products
- **Higher Rain Transparency**
 - L-band attenuation in heavy precipitation is significantly lower than C and Ku-band

Applications

- **Inner Core Resolution**
 - Reduced rain attenuation enables more consistent sampling of hurricane eye-wall and Radius of Maximum Winds
- **Airborne Campaign**
 - Planned to empirically characterize L-band performance and develop geophysical model functions across the full wind and precipitation regime.

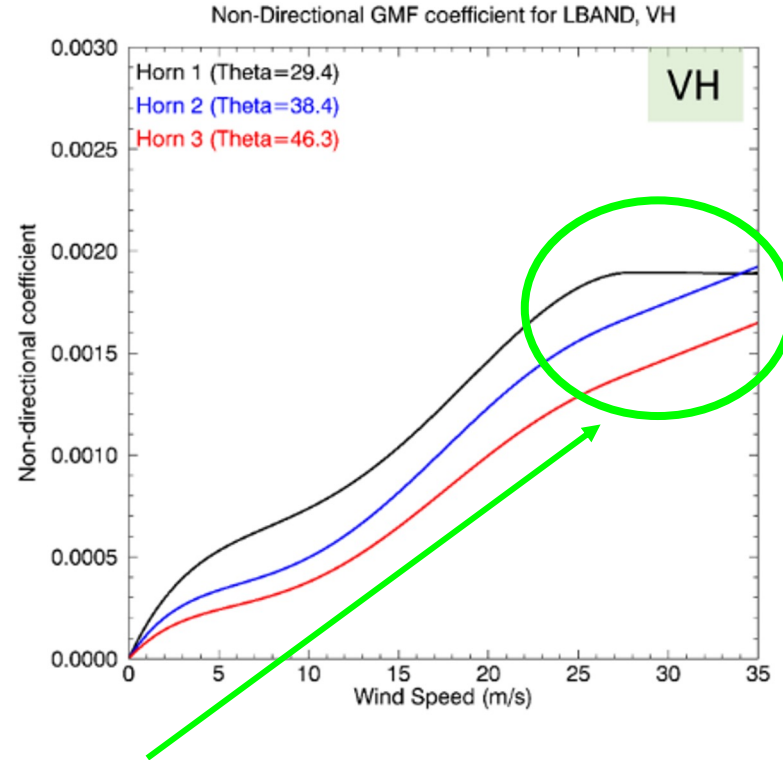
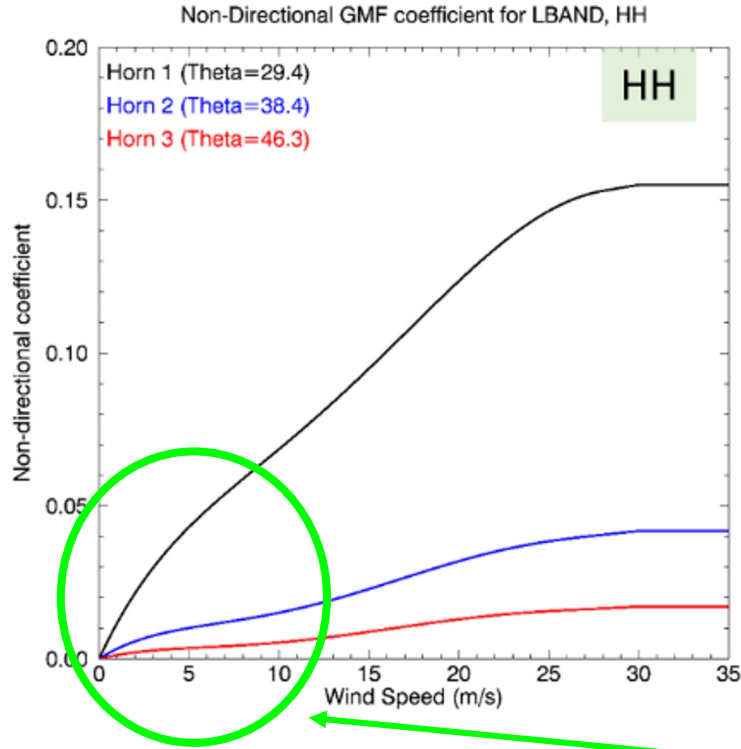

Aperture (-30dB / 0.001 NESZ) enables low wind speed measurement and a monotonic relationship beyond 35 m/s where other bands saturate

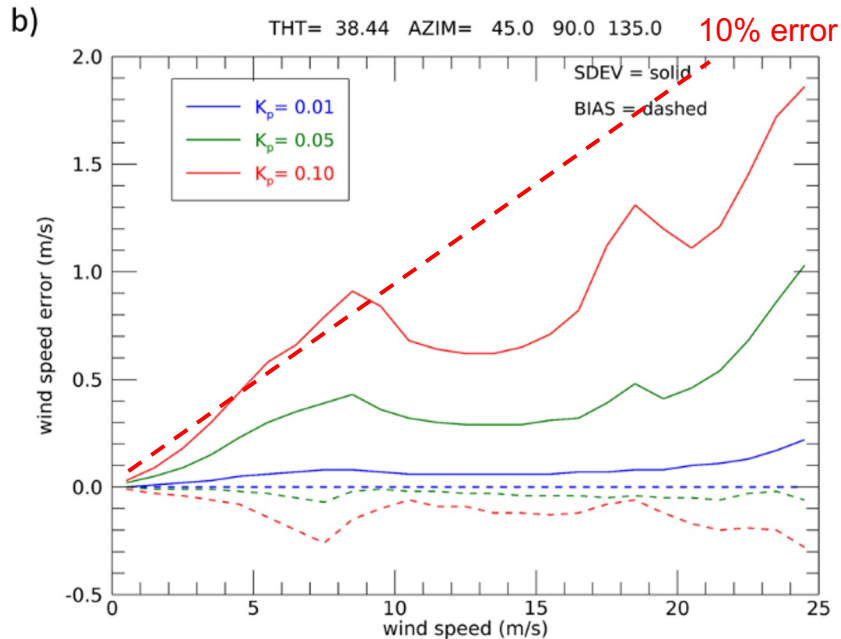
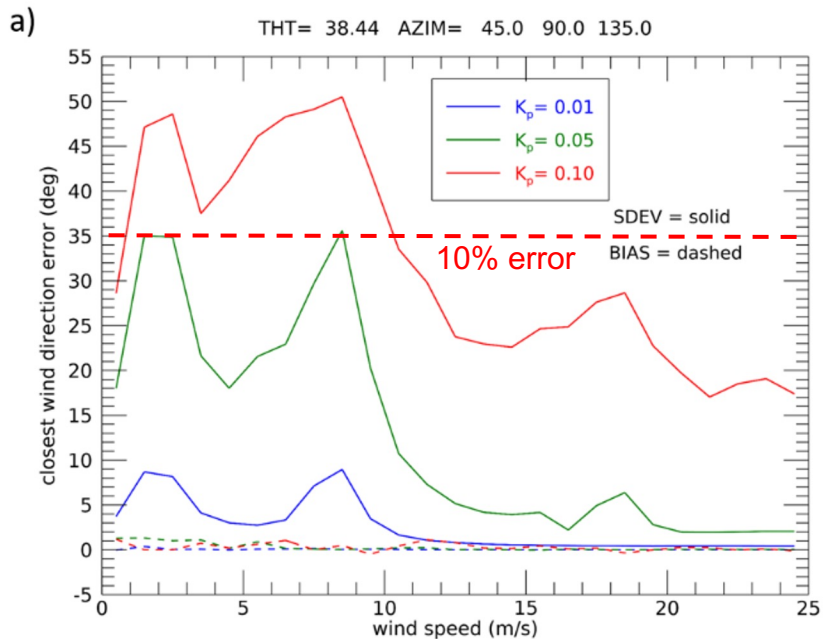

Aperture radiometric resolution (K_p) designed for 0.05 (green)

- 1.215 - 1.3 GHz Software Radar and Phased Array Antenna
direct RF sampling with RFI detection at native frequencies
- 16x 200W Tx / Parallel Rx channels for multiple
unique array phase centers
- Dual and Quad-polarization ESA (VV, VH, HV, HH)
for enhanced feature separation
- Reprogrammable On-Orbit
diverse mission profiles

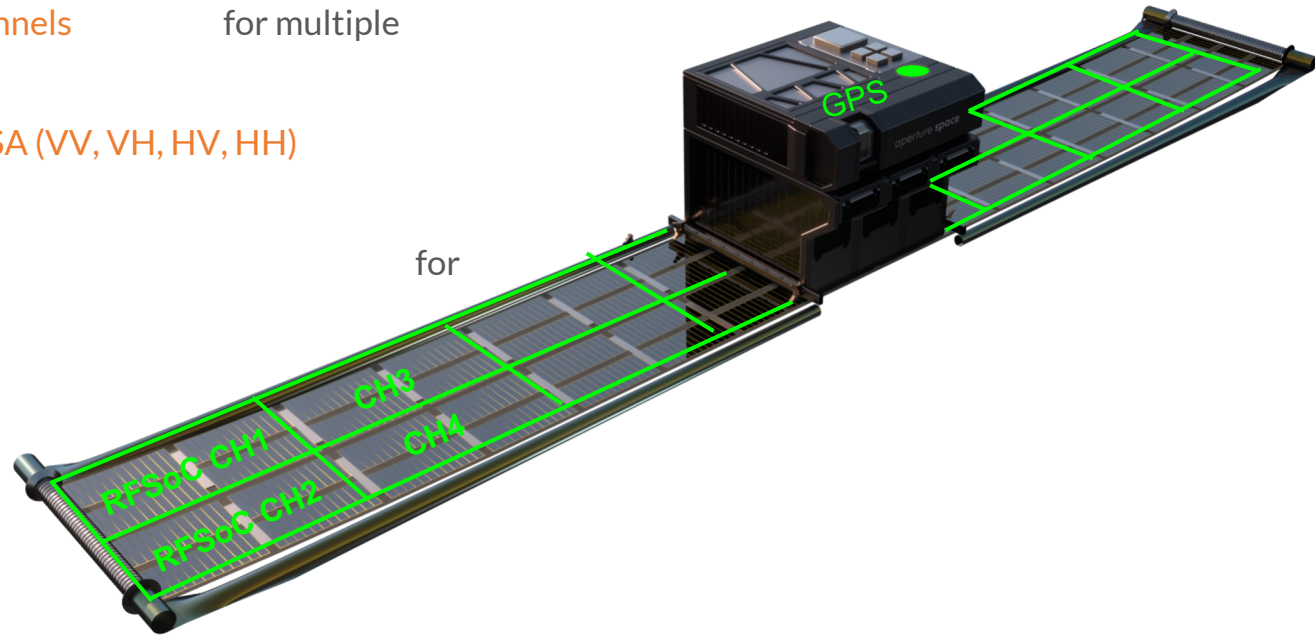

Operations

- Nadir Antenna covers 1200 km swath, electronically scans 132 beam positions
- Each beam sequences VV / VH
BW subdivided to increase 'looks'
- 9 km resolution via Radar Ranging and Doppler Beam Sharpening
- 1.6 mbps data rate with no preprocessing
- Nadir Altimetry capable

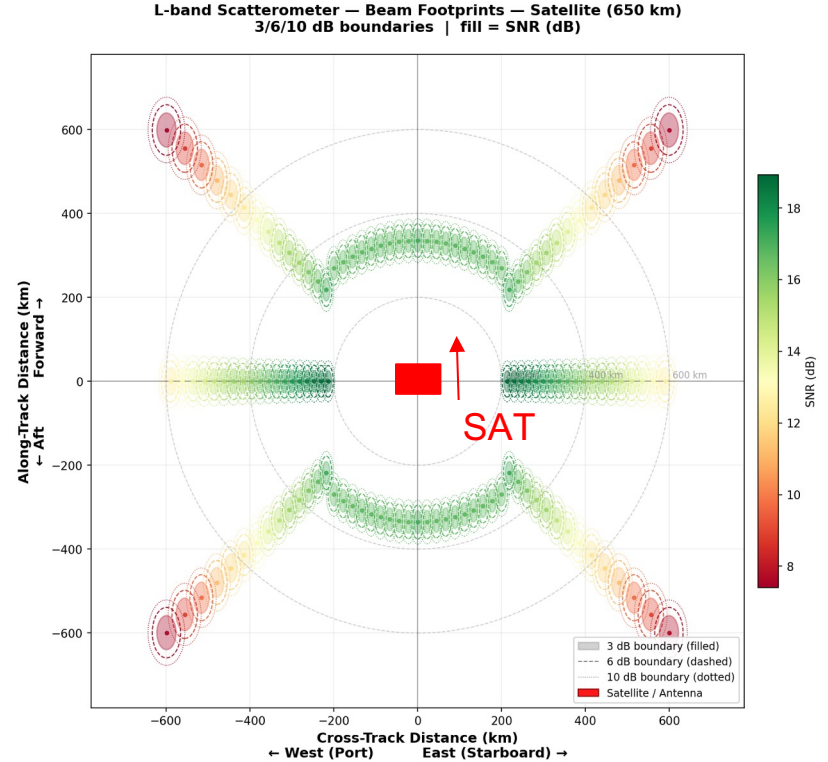

L-band Scatterometer - Performance

aperture

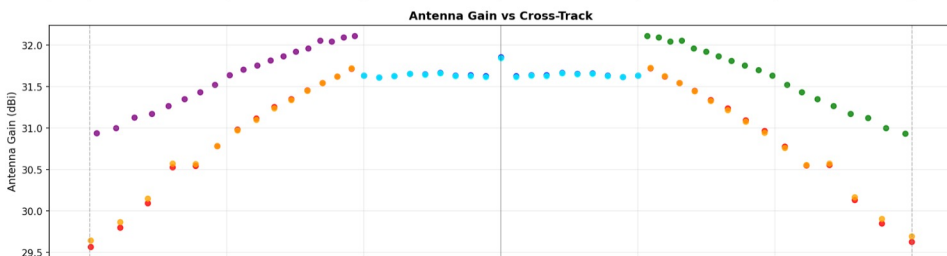
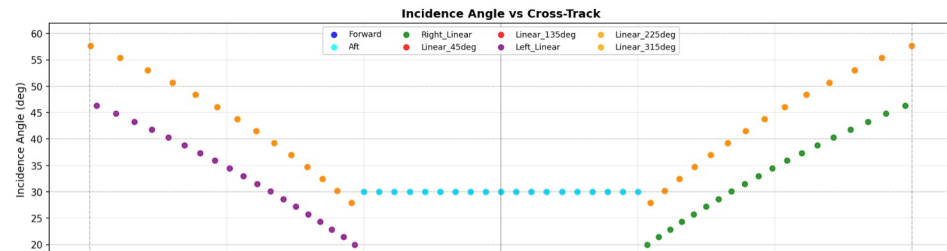
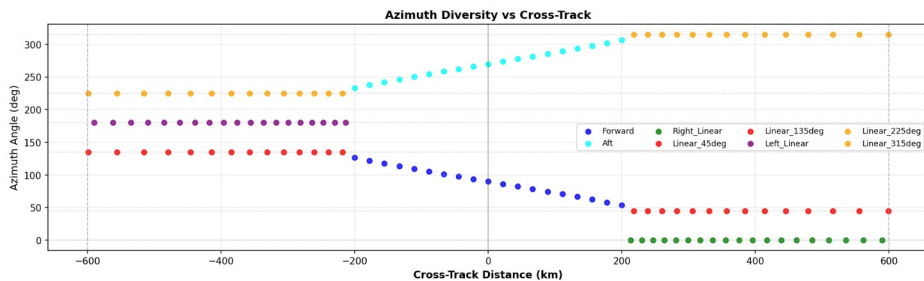
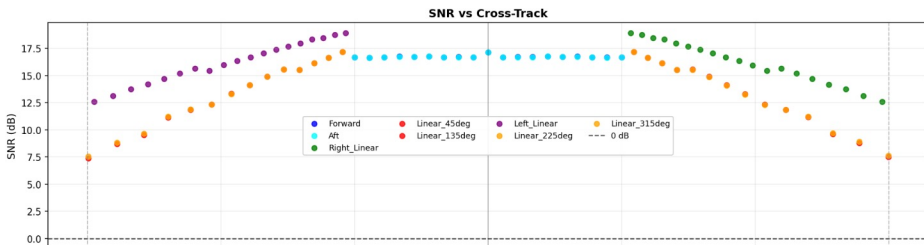

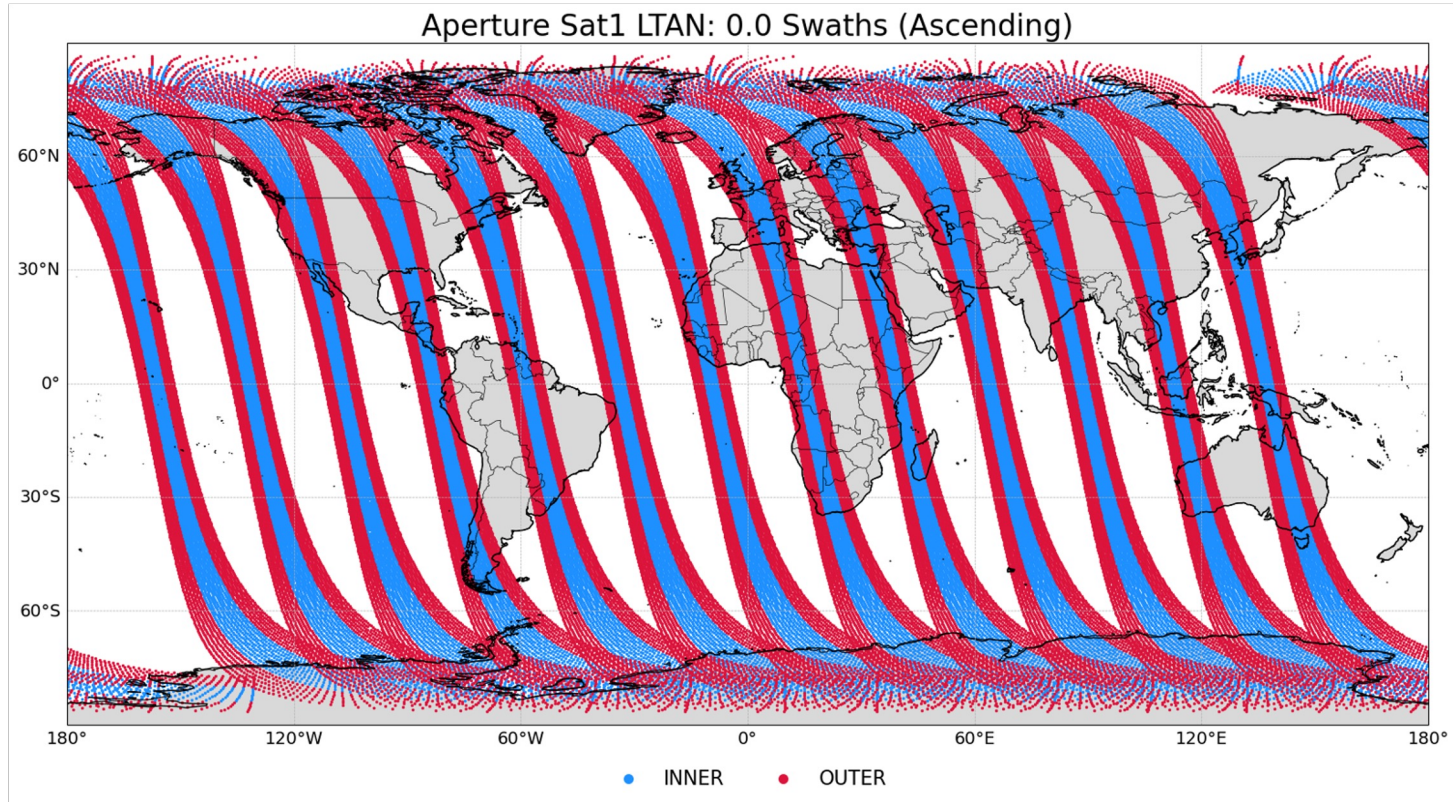

2024 Tropical Cyclone - Single SSO Satellite Intercept

aperture

1,000 km swath | SSO 650 km orbit | Within 250 km & 1.5 hrs of storm center

TOTAL NAMED STORMS BY BASIN — 2024

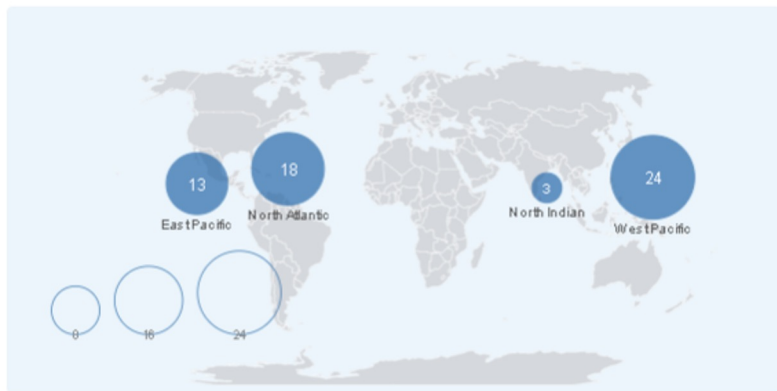

● Storm count

SATELLITE INTERCEPTS PER BASIN — 2024

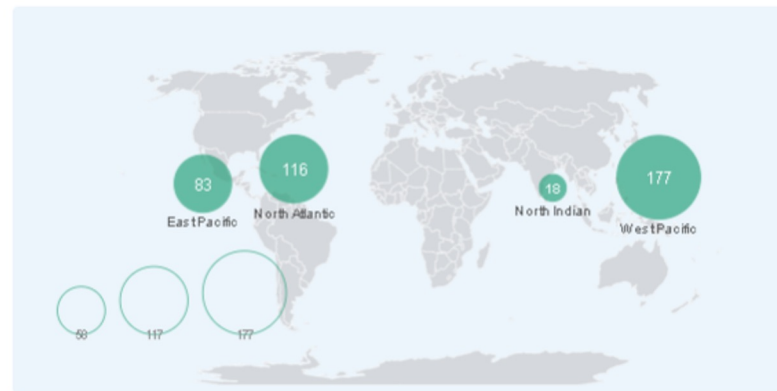

● Intercept count

58

Total named storms

394

Total satellite intercepts

6.8×

Avg intercepts per storm

~6 hr

Avg time between intercepts

2024 Tropical Cyclone - Satellite Intercept

aperture

Aperture Tropical 4, HELENE 1
Storm Time: 2024-09-23 12:00, Max Wind: 30.0 kt
Pass Avg Time: 2024-09-23 13:23, Interpolated Max Wind:
Time Diff (hr): -1.39

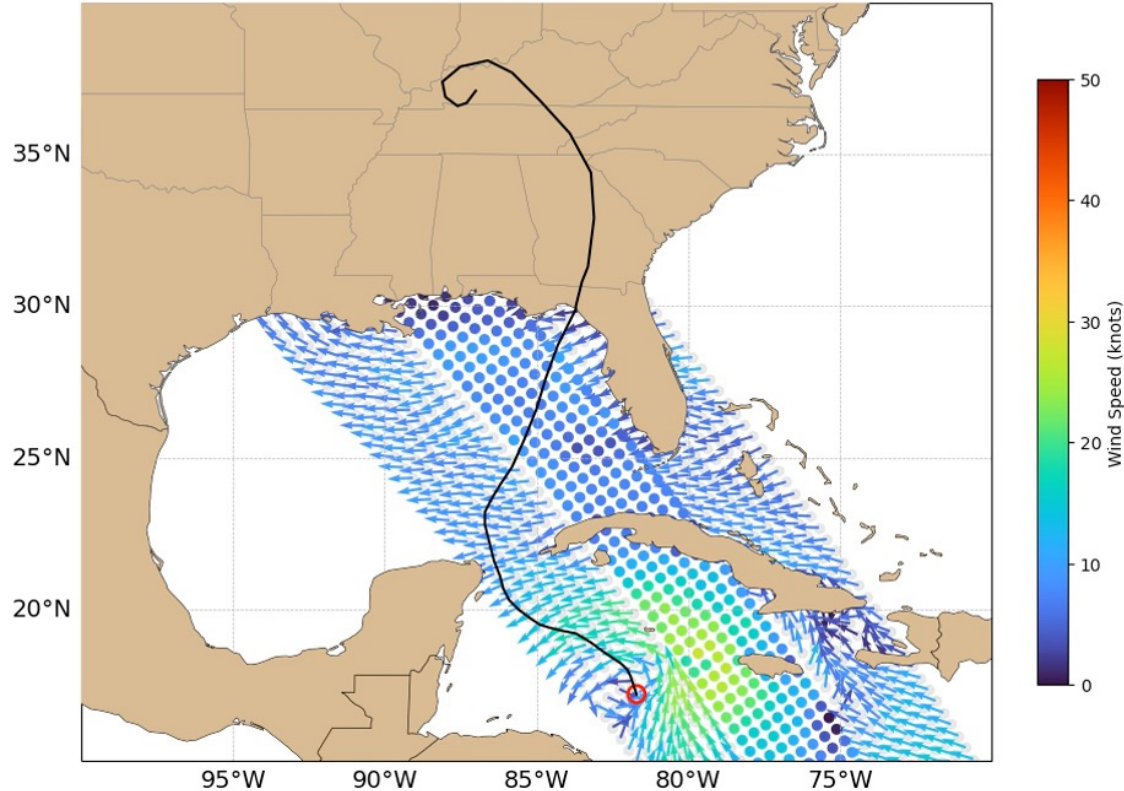

Platform & Operations Twin Otter based in Texas, flying sorties over the Gulf during peak Atlantic hurricane season (September–October 2026).

Co-collection Strategy Flight lines coordinated with ASCAT, OSCAT, and NISAR overpasses for simultaneous L-band, C-band, and Ku-band observations under identical conditions for direct cross-sensor comparison.

Validation Objectives Empirically characterize L-band backscatter across the full wind and rain regime and develop quad-pol geophysical model functions needed for operational wind retrieval.

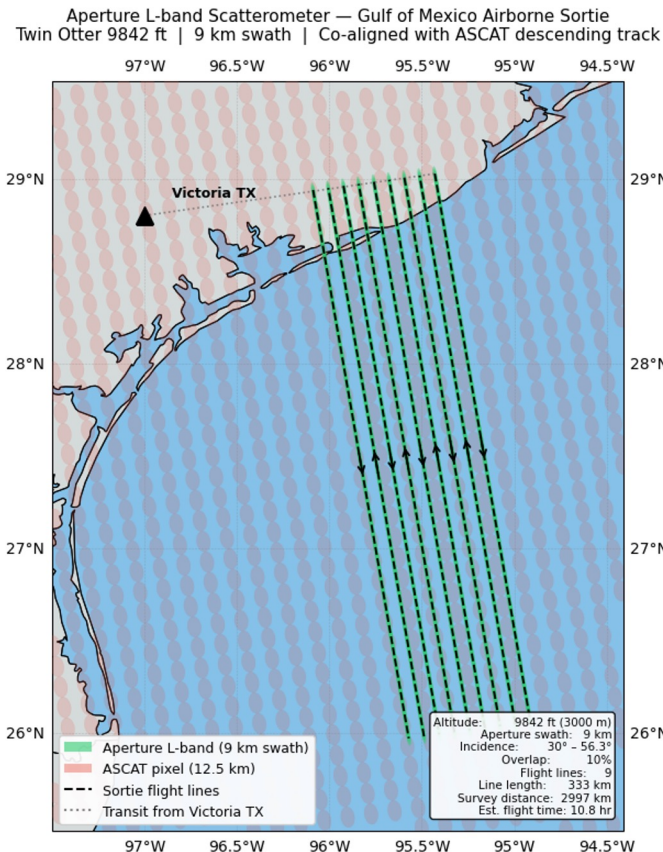

An aerial photograph of a vast agricultural landscape, showing a grid of fields and roads. The image is overlaid with a diagonal blue gradient that transitions from a light blue at the top left to a dark blue at the bottom right. The word "aperture" is centered in the middle of the image in a white, lowercase, sans-serif font.

aperture

CONTACT:
ZACH.KABELAC@APERTURE.EARTH